

BARS A TO BE EQUALLY SPACED FOR # OF BARS SEE TABLE BELOW

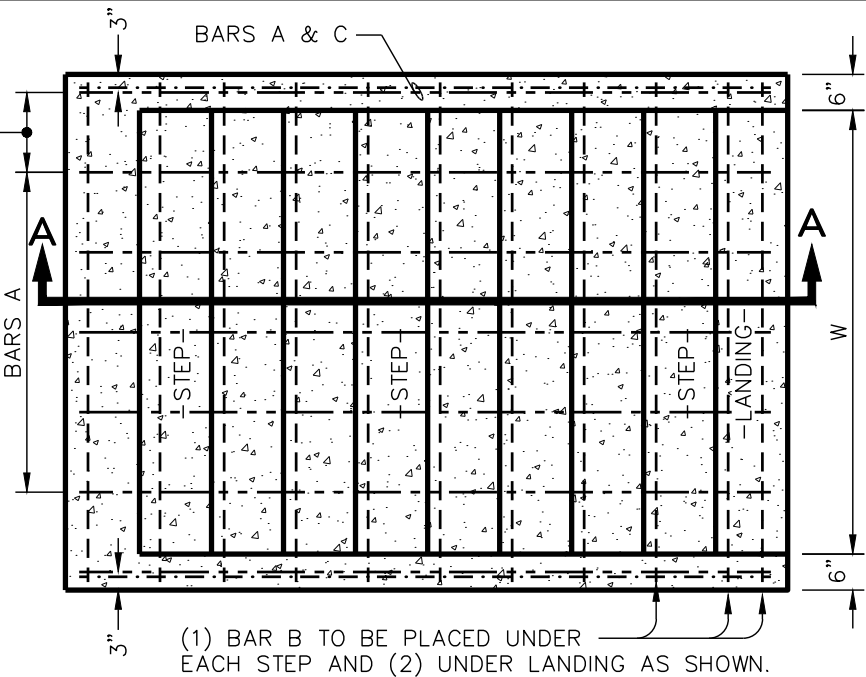

(1) BAR B TO BE PLACED UNDER EACH STEP AND (2) UNDER LANDING AS SHOWN.

**PLAN**

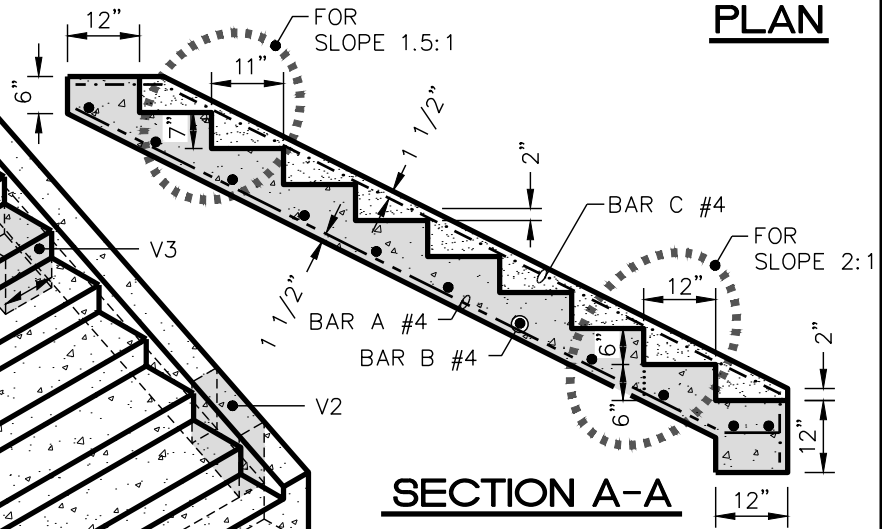
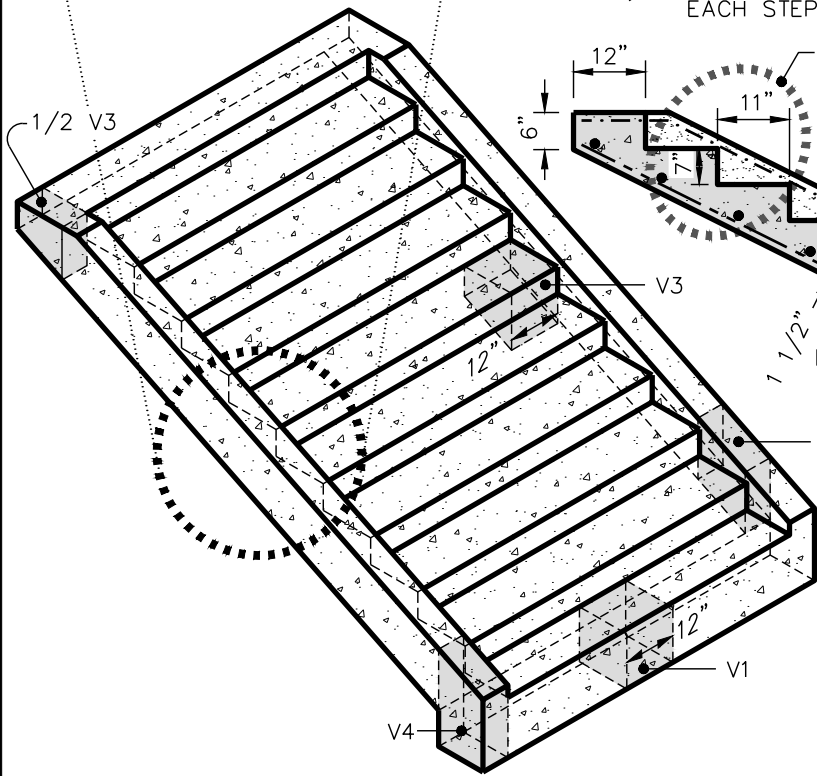

**SECTION A-A**

**LEGEND**

- BAR A
- BAR B
- BAR C

NUMBER OF BARS "A"									
NUMBER OF RISERS (N)	1-5	6	7	8	9	10	11	12	13-25
W=3'	NO STEEL	4	5	5	6	6	7	7	8
W=4'		5	6	7	7	8	8	9	10
W=5'		6	7	8	9	9	10	11	12

Details Provided by APPIAN Consulting Engineers - www.applanengineers.com



Dept. of Public Works  
101 City Hall Plaza  
Durham, NC 27701

**CITY OF DURHAM, NC**  
USE WITH THE STANDARD SPECIFICATIONS ONLY

Voice (919) 560-4326  
www.durhamnc.gov

**STANDARD CONCRETE STEPS  
(FOR 2:1 SLOPES)**

SCALE: Not to Scale	DETAIL# 409.01
REVISION DATE: 06/2017	SHEET# 1 of 3